

Maintenance Manual

Series 860 Reduced Pressure Zone Assemblies Models 860, LF860, 860U & LF860U 1/2" - 2" (15 – 50mm)



Table of Contents

Feature and Operating Procedures	2
Vandalism	2
General Service Procedures	3
Cut-A-Way Drawing	3
Troubleshooting Guide	4
Check Module Disassembly	6
Check Module Seal Replacement	6
Check Module Re-Assembly	7
Relief Valve Repair	7
Testing	9
Air Gap Drain Installation Instructions	9
Exploded View	10
Parts List	10
Repair Kits	11
Freeze Protection	11
Main Valve Draining Procedure (1/2" - 2")	11
Warranty	12

Read and understand this manual prior to installing, operating or servicing this equipment.



A black triangle with a white exclamation mark inside, indicating a warning.**WARNING**

IMPORTANT: You are required to thoroughly read all installation instructions and product safety information before beginning the installation of this product. **FAILURE TO COMPLY WITH PROPER INSTALLATION AND MAINTENANCE INSTRUCTIONS COULD RESULT IN PRODUCT FAILURE WHICH CAN CAUSE PROPERTY DAMAGE, PERSONAL INJURY AND/OR DEATH.** FEBCO is not responsible for damages resulting from improper installation and/or maintenance. Local building or plumbing codes may require modifications to the information provided. You are required to consult the local building and plumbing codes prior to installation. If this information is not consistent with local building or plumbing codes, the local codes should be followed.

Need for Periodic Inspection/Maintenance: This product must be tested periodically in compliance with local codes, but at least once per year or more as service conditions warrant. Replace internal components every 5 years. Corrosive water conditions, and/or unauthorized adjustments or repair could render the product ineffective for the service intended. Regular checking and cleaning of the product's internal components helps assure maximum life and proper product function.

Feature and Operating Procedures

The FEBCO Series 860 Reduced Pressure Zone Backflow Preventer Assembly consists of two independently operating, spring loaded check valves with a pressure differential relief valve located between the two checks. The pressure drop across the first check valve is approximately 7.0 psid with no flow. The relief valve consists of a hydraulically balanced diaphragm with the high pressure side hydraulically connected to the upstream pressure zone. The relief valve remains closed during normal operation. The low pressure side of the diaphragm is spring loaded to force the relief valve to open when the pressure drop the first check and the diaphragm is reduced to approximately 3.0 psid. A complete assembly includes two shutoff valves and four test cocks.

Vandalism

If the unit is installed where vandalism may be a problem, the assembly should be protected and secured. On 1/2" through 2" (15 – 50mm) units the handles of shutoff valves can be removed to discourage tampering. A protective enclosure can be installed over the unit to discourage vandals. If an enclosure is used, it should be installed so that adequate clearance is available for maintenance and testing. Consult local codes before installing any type of protective enclosure.

General Service Procedures

1. FEBCO backflow prevention assemblies can be serviced with standard tools and are designed for ease of maintenance. The assemblies are designed to be serviced in line, so the unit does not need to be removed from the line during servicing. **NO special tools are required.**

Suggested Tool Kit Series 860 1/2" - 2"(15 - 50mm)

- 1 crescent wrench
 - 1 medium standard screw driver
 - Differential pressure test kit
 - 1 medium Phillips screw driver
 - Box/open end wrench
2. The most common cause of check fouling and relief valve discharge is dirt and debris in the seating areas. The line should be flushed clean of debris before installation of the assembly. To flush the line after installation of the assembly, slowly close the inlet shutoff valve, remove the cover and spring assemblies of both check valves and open the inlet shutoff valve to allow sufficient flow of water through the assembly to clear all sand, debris, etc. from the line. If debris in the water continues to cause fouling, a strainer may be installed upstream of the assembly (check local codes).

3. Rinse all parts with clean water before reassembly.
4. Carefully inspect diaphragms, seals, and seating surfaces for damage or debris. If the check valve seat disc has been severely cut at the seat ring diameter, the assembly has been subjected to extremely high and repeated back pressure. Either thermal water expansion or water hammer are the most likely causes. If back pressure persists, consider installation of a pressure relief valve downstream of the assembly.
5. Use caution to avoid damaging any guiding surfaces while handling parts. Do not force parts together. The O-ring seals used in FEBCO assemblies require only a small tightening force to ensure a positive seal.
6. Test unit after servicing in accordance with locally approved test methods to ensure proper operation (See page 9 for more details).
7. Refer to applicable exploded drawings and parts lists (pages 10-11) for visual aid information.
8. Apply a thin coating of the lubricant supplied in the repair kit to the O-rings and other seals as directed in this manual. Use of additional lubricants must be FDA approved food grade petroleum jelly.

Cut-A-Way Drawing

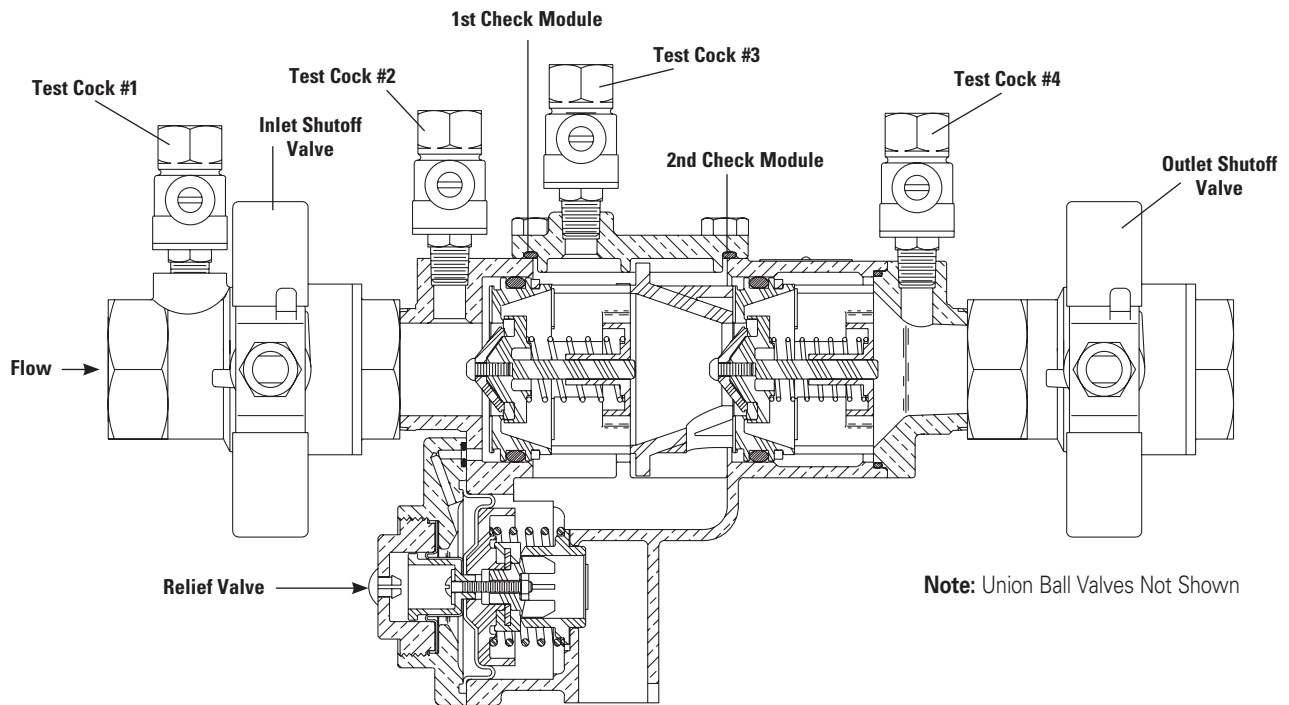

Troubleshooting Guide

With Differential Pressure Gauge

SYMPTOM #1	READING	PROBLEM:
Check Differential Across #1 Check Valve	2 to 3 psid	Leak in #1 or #2 check valve
	6 to 8 psid and steady	Malfunctioning pressure relief valve
	2 to 7 psid and steady	Inlet pressure fluctuating

SYMPTOM #2	READING	PROBLEM:
Check Differential Across #1 Check Valve	2 to 3 psid	#1 check valve held open
	6 to 8 psid and steady	Malfunctioning pressure relief valve

Without Differential Pressure Gauge

SYMPTOM #1 AND #2	RESULT	PROBLEM:
A) Close Gate Valve #2	If discharge stops	Leak in #2 check valve
	If discharge does not stop	Go to "B"
B) Open #4 test cock to produce a flow greater than differential relief valve discharge	If discharge stops	Leak in #1 check valve
	If discharge does not stop	Malfunctioning pressure relief valve

SYMPTOM #1	CAUSE:	SOLUTION:
Continuous discharge from relief valve during NO FLOW conditions (Discharge stops with water flow) With this symptom, the pressure drop across the #1 check valve would be 2 to 3 psid. If a flow of water (more than discharge) is created through the valve, the pressure drop should increase to approximately 7psi	A. Debris fouling #1 check valve	Inspect and clean
	B. Outlet pressure higher than inlet pressure and debris fouling #2 check valve	Inspect and clean
	C. Spring stem not moving freely	Inspect for dirt or other foreign material
	D. Damaged seat or seat disc	Inspect and replace. If necessary, seat disc can be reversed in 1/2" through 2" sizes
	E. Leakage at check module O-ring	Inspect and replace seal or O-ring

SYMPTOM #2	CAUSE:	SOLUTION:
Intermittent discharge from relief valve during NO FLOW conditions. With the symptom, the pressure drop across the #1 check valve would be varying from about 2 to 7 psid	A. Inlet line pressure variations causing relief valve to discharge	Eliminate or reduce pressure variations by installing a soft seated, spring loaded check on upstream side of device
	B. Pressure surges (water hammer) causing relief valve to discharge as pressure wave passes through the zone	Eliminate or reduce pressure surges

Troubleshooting Guide (Continued)

SYMPTOM #3	CAUSE:	SOLUTION:
Continuous discharge from relief valve during FLOW and NO FLOW conditions With this symptom, the pressure drop across the #1 check valve would be 7 psid or more at all times	A. Seat disc dislodged from cavity in the main stem. (This can be caused by pressure surges during initial filling of system lines.)	Reposition disc in main stem cavity Repressurize system slowly
	B. Debris fouling the relief valve seat	Inspect and clean
	C. Debris blocking the relief valve sensing passage	Inspect and clean
	D. Dirt or scale jamming main stem	Inspect and clean, or replace
	E. Leakage at main stem	Inspect and clean, or replace

SYMPTOM #4	CAUSE:	SOLUTION:
Relief valve does not open above 2.0 psid during field testing	A. Outlet gate valve not closed completely	Inspect and clean
	B. Plugged low pressure hydraulic passage (from "ZONE" to inner diaphragm)	Inspect and clean
	C. Improper alignment of internal parts during reassembly (causing high resistance to movement)	Reassemble
	D. Jammed main stem due to debris Check for debris blocking gate valve	Clean

SYMPTOM #5	CAUSE:	SOLUTION:
First check pressure drop is low (less than 5 psid) during field testing	A. Debris fouling first check seat	Inspect and clean
	B. Debris fouling second seat with backpressure	Inspect and clean
	C. Inlet pressure variations causing inaccurate gauge reading	Eliminate pressure variations (see symptom #2A)
	D. Damaged seat or seat disc	Inspect and clean as required
	E. Worn guide, bushing or stem	Inspect and replace as required

SYMPTOM #6	CAUSE:	SOLUTION:
Second check fails to hold back pressure during field testing	A. Outlet gate valve not closed completely	Inspect and clean
	B. Debris fouling second check seat	Inspect and clean
	C. Damaged seat or seat disc	Inspect and replace if required
	D. Worn guide, bushing or stem	Inspect and replace if required

Check Module Disassembly

1. Slowly close inlet and outlet ball valves. Bleed residual pressure by opening #2, #3, and #4 test cocks. Allow the test cocks to remain open until the reassembling is completed. Test cock #1 should remain closed.
2. Remove the cover bolts (Item 21) using the appropriate size wrench.
3. Remove spacer (Item 8) by grasping the flanged end of the spacer and pulling straight up.

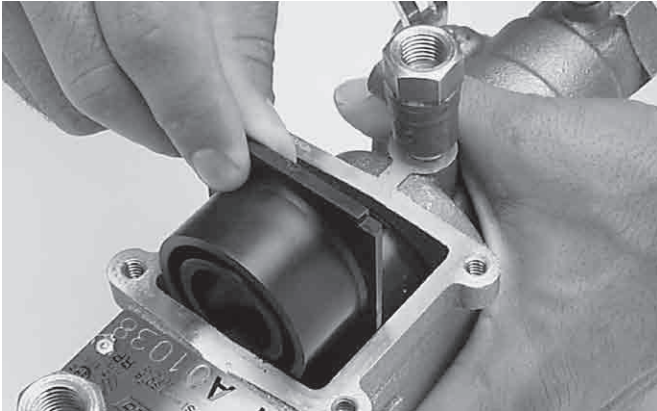

4. Remove the inlet check assembly by pulling it in the direction of flow out from the body bore until it is completely exposed then lift out of the body.
5. Remove the outlet check assembly by placing the tip of a medium size flat nose screw driver in the slot of the seat (Item 3) and prying the check assembly back until the red O-ring (Item 3.1) is exposed. Then, using your fingers, pull it out from the body bore until it is completely exposed then lift out of the body.

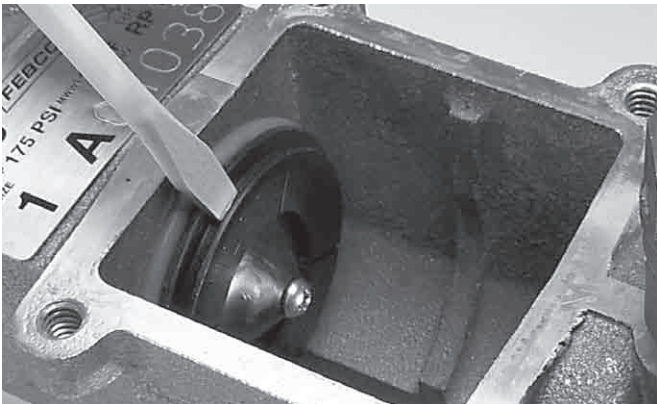

Check Module Seal Replacement

Both check assemblies are disassembled and reassembled in the same manner. To service the checks, you may replace the check modules with new ones by using check module assembly kits available from FEBCO. Or, you may also replace the rubber components in the check modules by using the replacement rubber parts kits available from FEBCO. For details on parts and kits, please see pages 10 - 12.

1. To disassemble, grasp the seat section (Item 6) in one hand and the guide section (Item 7) in the other hand and then rotate in a counter clock wise direction (approx. 1/8 turn) until the two parts disengage.

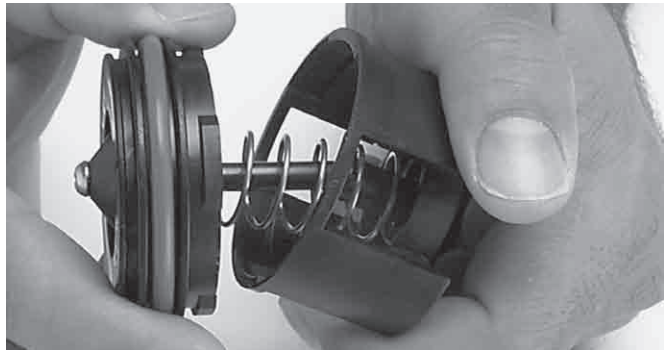

2. Remove retaining screw (Item 5.2) and disc retainer (Item 5.1) so the rubber disc is fully exposed. Carefully pry out the rubber disc from poppet. Be careful not to damage the poppet when removing the disc. Rinse poppet in clean water and replace the old rubber disc with new rubber disc. If the rubber disc is not damaged, it can be reversed and reinstalled when a new disc is not available. Rinse all other internal components with clean water. Replace disc retainer and secure with retaining screw (Item 5.2).



3. Reassemble check module in the reverse manner as indicated in above. When reassembling the check module, be sure to insert the poppet stem into the guide hole and keep fingers clear of the slots in the module.

Check Module Re-Assembly

Use reverse procedure for assembly with the following special instructions.

1. Inspect the check module O-ring (Item 3.1) for damage and replace if necessary. To ease assembly, apply a thin coating of supplied lubricant to the O-ring (Item 3.1) prior to installing in body.

CAUTION:

Excess lubricant may cause foreign debris to collect on internal components which could foul the check assembly and result in a test failure.

2. The word **INLET** is inscribed on the end of each module. That end should face the inlet of the valve.

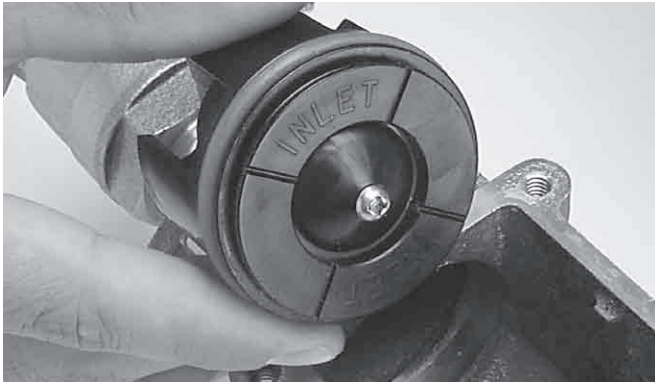

3. When installing the check modules on the Series 860 Reduced Pressure Assembly, make sure the check assembly with the heavy duty spring is inserted in the inlet bore of the body (1st check position). Ensure the orientation of the 1st check assembly is positioned so that one (1) of the four (4) flow path windows faces down towards the Relief Valve. The check assembly with the weaker spring must be installed in the outlet bore of the body (2nd check position).

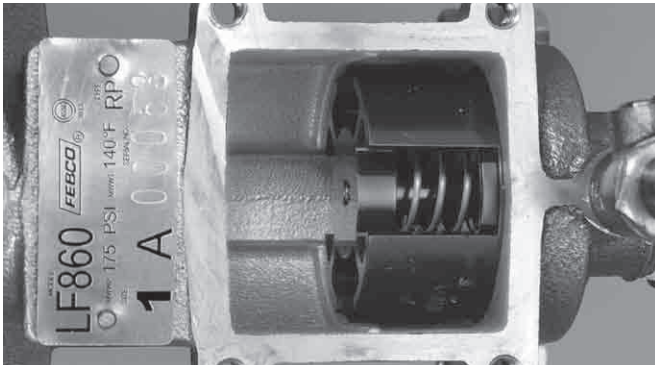

4. When replacing spacer (Item 8) between the two check assemblies, be sure that the flanged end of the spacer is touching the back side of the inlet check assembly so that the cover will fit properly. Next, replace cover making sure #3 test cock is on the upstream side. Do not over tighten cover bolts (Approximately 35 inch-pounds is sufficient).
5. After reassembling, close test cock #2, #3 and #4 (test cock #1 should already be closed), slowly open inlet ball valve. Bleed air from the unit by opening and closing test cock #2, then #3 and finally #4.
Note: During the bleeding process on the Series 860, the relief valve may discharge a high volume of water until all test cocks have been closed and pressure stabilized.
6. Check for external leaks and repair if necessary. Slowly open outlet ball valve.
7. Test assembly in accordance with the locally approved test methods.

Relief Valve Repair

NOTE: Discharge from the relief valve assembly may not indicate a relief valve failure. The relief valve will discharge water when the mainline check valves become fouled with foreign debris. See Troubleshooting Guide for more information **BEFORE** disassembling the relief valve.

1. Slowly close inlet and outlet ball valves. Bleed off air from the unit by opening and closing test cock #2, then #3, and finally #4. Test cock #1 should remain closed.
2. Loosen brass cylinder in center of relief valve cover (Item 18) by unscrewing 1/4 turn (counterclockwise). Remove the relief valve cover bolts (Item 21) and relief valve cover (Item 19).
3. The internal relief valve assembly module will be attached to the relief valve cover. Unscrew the brass cylinder and remove from cover. Grasp the outer diameter of the large outer diaphragm (Item 15) and pull away from the cover until the small outer diaphragm (Item 16) comes out through the relief valve cover hole and is completely separated from the relief valve cover. Discard old internal relief valve assembly module. Remove the plastic slip rings (Item 18.1) and discard. Slide out the seat ring (Item 12) and seat gasket ring (Item 12.1) from the relief valve body and discard.

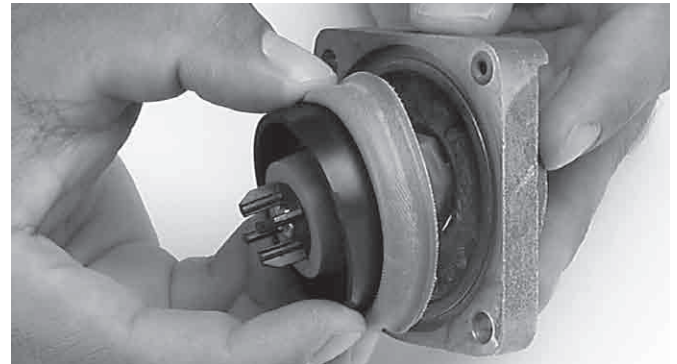

4. Apply a thin coating of supplied lubricant to both sides of the new seat gasket ring (Item 12.1), and slide it on the short end of the new seat ring (Item 12). Slide the short end of the new seat ring into the hole of the relief valve body. (The adhesion from the lubricant will hold the seat ring in place during the rest of the assembly process.)

Relief Valve Repair - continued

5. Before installing the new internal relief valve assembly module, apply a thin coating of supplied lubricant to both sides of one slip ring (Item 18.1) and insert it into the top of the relief valve cover. Install the new internal relief valve assembly module by grasping the outside of the outer diaphragm in one hand and the smaller diaphragm in the other hand. Then pull upward gently on the small outer diaphragm (Item 16) so that it forms the shape of a tulip. Hold the small diaphragm so that it maintains this "tulip" shape while sliding it through the relief valve cover hole and plastic diaphragm gasket.

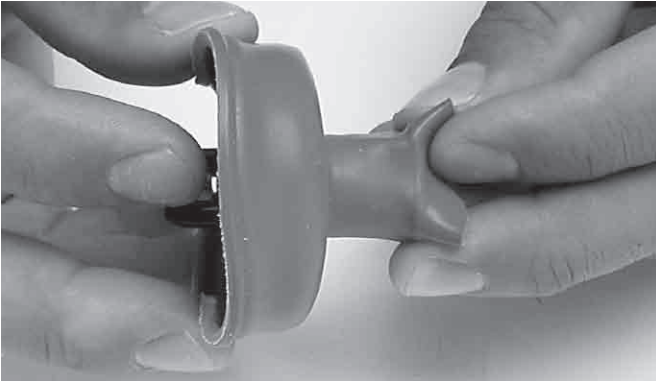

6. Apply a thin coating of supplied lubricant to both sides of the second slip ring (Item 18.1) and place it over the top of the small diaphragm making sure the outer diaphragm (Item 16) is not folded or creased under the slip ring. Push the slip ring down flat until the adhesion from the grease holds the small diaphragm in place. This should roll the diaphragm as shown. Thread the brass cylinder (Item 18) into the relief valve cover and hand tighten.

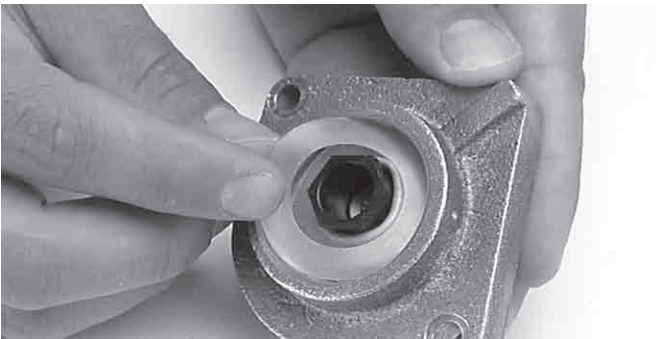

Caution: Do not twist the internal parts when the cylinder is tightened. The small diaphragm may become folded or creased if the internal assembly is restricted while tightening the cylinder.

7. Replace O-ring (Item 20) in relief valve cover. Make sure the round bead on the large diaphragm is properly seated in the counterbore of the relief valve cover. Position spring (Item 13) over the seat ring in the relief valve body and hold in place while inserting the guide end (Item 23) of the relief valve assembly module and relief valve cover. Position the assembly so the O-ring aligns with the sensing hole in the body and the guide slides into the seat ring. Replace relief valve cover bolts and tighten to approximately 35 inch-pounds. **Do not over tighten.** Tighten the brass cylinder (Item 18) in the relief valve cover to approximately 30 feet pounds of torque. **Do not over tighten.**

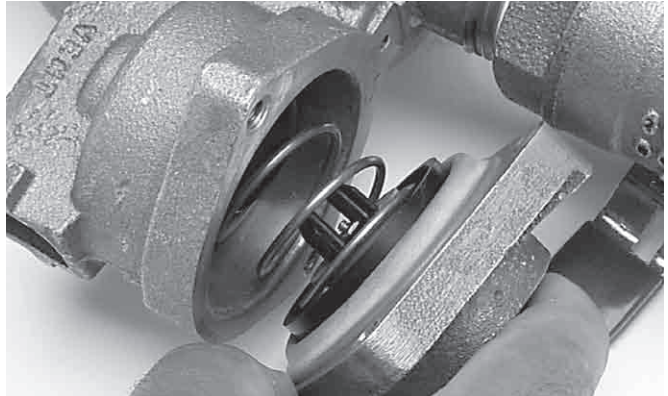
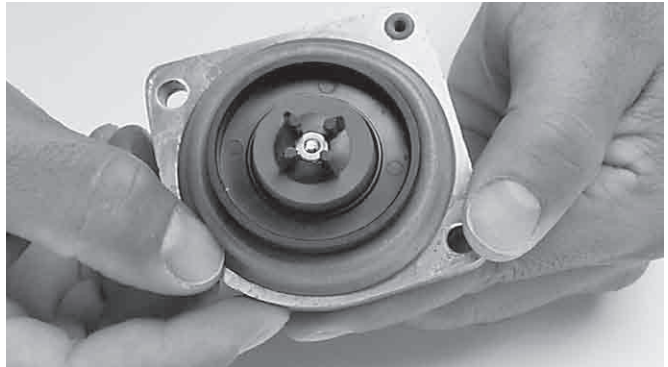

8. After reassembly, with all test cocks closed, slowly open inlet ball valve and bleed air from the unit by opening and closing test cock #2, then #3 and finally #4. **NOTE:** During the bleeding process, the relief valve may discharge a high volume of water until all test cocks have been closed and pressure has been stabilized.

9. Check for external leaks and repair if necessary. Slowly open outlet ball valve.

10. Test assembly in accordance with the locally approved test method.

Testing

All mechanical devices should be inspected on a regular basis to ensure they are working correctly. The assembly should be tested at time of initial installation, after servicing or maintenance, and at least annually thereafter. Acceptable test procedures are published by Foundation for Cross-Connection Control and Hydraulic Research at the University of Southern California (USC), The American Water Works Association (AWWA), The American Society of Sanitary Engineering (ASSE Series 5000) and the Canadian Standards Association (CAN/CSA B64•10). Please consult the regulatory authority in your area for more specific information.

Air Gap Drain Installation Instructions

1. Before installation check local codes. This type of drain may not be approved for use in some areas.

CAUTION:

This drain is intended to catch moderate relief valve discharges due to line pressure fluctuations and minor check valve fouling. Under certain conditions relief valves can discharge water at rates greater than the air gap drain capacity.

2. If installed indoors, the assembly should be installed near a floor drain sized to adequately handle discharge. A Strainer before the backflow assembly is strongly suggested on indoor installation.
3. After installation of backflow assembly and piping, attach drain funnel to relief as shown, using self tapping screws provided in kit to join drain funnel halves together, making sure that the slots in the drain funnel are located over tabs on relief valve port.

Note: Discharge of drain funnel is a slip fit design. Drain funnel was not designed to, nor is it able to support drainpipe weight.

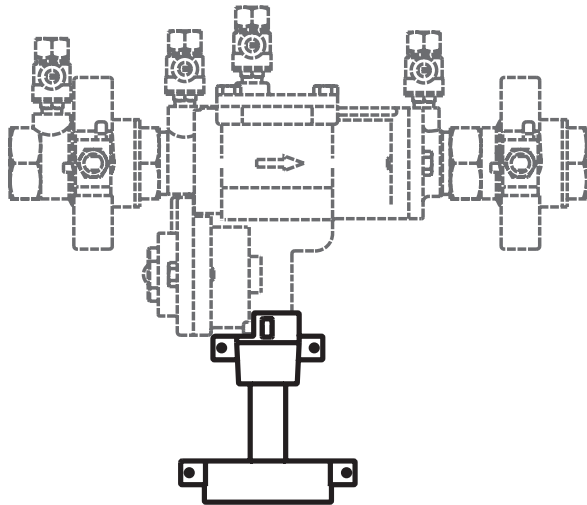

Air Gap Part Number

VALVE SIZE	PLASTIC PART NO.	METAL PART NO.
1/2"	905358	905532
3/4"	905358	905532
1"	905358	905532
1 1/4"	905359	905533
1 1/2"	905359	905533
2"	905359	905533

Exploded View

ITEM	DESCRIPTION	QUANTITY
1	Body	1
1.2	Tailpiece	1
1.4	O-Ring	1
2	Cover	1
2.2	O-Ring	1
3	Seat	2
3.1	O-Ring	2
3.2	Inlet Ring (1 1/4" & 1 1/2")	1
4	Poppet	2
5	Seat Disc	2
5.1	Disc Retainer	2
5.2	Round HD Screw	2
6	Spring (1st Check Spring)	1
6.1	Spring (2nd Check Spring)	1
7	Guide	2
8	Retainer Spacer	1
9*	Ball Valve Tapped Union End BV Tapped	1
9.1*	Ball Valve Union End Ball Valve	1
11	Test Cock	4
12	Seat Ring - RV	1
12.1	Gasket Ring - RV	1
13	Spring - RV	1
14	Seat Disc - RV	1
15	Diaphragm - RV	1
16	Outer Diaphragm - RV	1
17	Small Piston - RV	1
17.1	Round HD Screw - RV	1
17.2	Washer - RV	1
17.3	Hex Nut - RV	1
18	Cylinder - RV	1
18.1	Slip Ring Cylinder - RV	1
18.2	Slide (Plug) - RV	1
19	Cover - RV	1
20	O-Ring - RV	1
21	Hex HD Capscrew	*
22	Large Piston - RV	1
23	Guide - RV	1

* Quantity varies with valve size;
6 each for 1/2" and 3/4", 8 each for 1",
14 each 1 1/4", 1 1/2", 2"

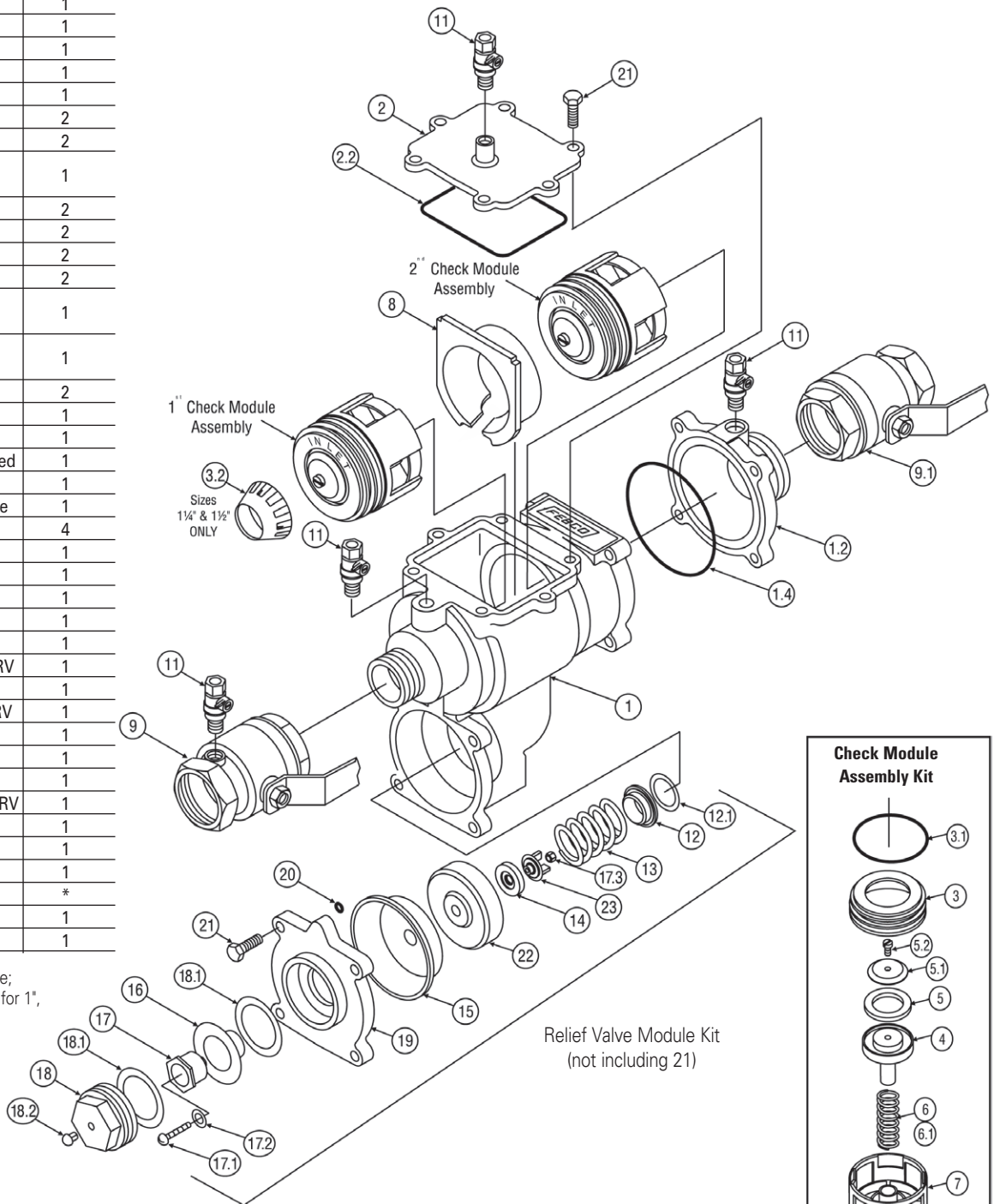

Relief Valve Module Kit
(not including 21)

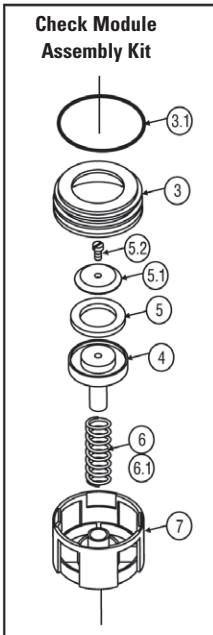

View as shown is for sizes 1 1/2" - 2" (40 - 50mm)

Repair Kits

How to order parts and Repair Kits

1. Locate item number and kit number in this maintenance manual.
2. Verify the size of the valve the parts are to be used on.
3. Provide full model number located on I.D. plate.
4. Give kit number.
5. A serial number (located on the I.D. plate) will assist in ordering the proper kits.
6. Contact your local FEBCO Parts Distributor.

	ORDERING CODE	STYLE	SIZE	
			<i>in.</i>	<i>mm</i>

Complete Rubber Kit

LEAD FREE	905355	ALL	1/2 & 3/4	15 & 20
	905356	ALL	1	25
	905357	ALL	1 1/4 - 2	32 - 50

Kit Includes: All rubber parts

Check Module Rubber Kit

LEAD FREE	905342	ALL	1/2 & 3/4	15 & 20
	905343	ALL	1	25
	905344	ALL	1 1/4 - 2	32 - 50

Both checks. Kit Includes: Item 2.2 & 2 ea. of items 3.1 & 5

Relief Valve Rubber Kit

LEAD FREE	905345	ALL	1/2 & 3/4	15 & 20
	905345	ALL	1	25
	905346	ALL	1 1/4 - 2	32 - 50

Kit Includes: Items 12, 12.1, 14 - 16, 18.1 (2 ea) & 20

Single Poppet Kit

LEAD FREE	905339	ALL	1/2 & 3/4	15 & 20
	905340	ALL	1	25
	905341	ALL	1 1/4 - 2	32 - 50

Valve has two poppets. Kit Includes: Items 4 thru 5.2

	ORDERING CODE	STYLE	SIZE	
			<i>in.</i>	<i>mm</i>

#1 Check Module Kit (inlet)

LEAD FREE	905348	ALL	1/2 & 3/4	15 & 20
	905350	ALL	1	25
	905352	ALL	1 1/4 - 2	32 - 50

Kit Includes: Items 3 - 7 for inlet check

#2 Check Module Kit (outlet)

LEAD FREE	905347	ALL	1/2 & 3/4	15 & 20
	905349	ALL	1	25
	905351	ALL	1 1/4 - 2	32 - 50

Kit Includes: Items 3 - 7 for outlet check

Full Relief Valve Module Kit

LEAD FREE	905353	ALL	1/2 & 3/4	15 & 20
	905353	ALL	1	25
	905354	ALL	1 1/4 - 2	32 - 50

Kit Includes: 1 ea of Items 12 - 17.3, 20, 22 & 23 & 2 ea. of 18.1

*The wetted surface of this product contacted by consumable water contains less than one quarter of one percent (0.25%) of lead by weight.

Freeze Protection

The backflow prevention assembly may be subject to damage if the internal water is allowed to freeze. The unit must be protected from freezing using a heated enclosure, insulation using heat tape, or other suitable means. The unit must always be accessible for testing and maintenance. If the system will be shut down during freezing weather, use the following procedures to drain internal passages.

Ball Valve Shutoff Draining Procedure

If the assembly has been installed with ball valve shutoff valves, they must also be properly drained to prevent freeze damage. After draining procedure has been completed on the backflow prevention assembly, position all ball valve shutoffs and test cocks in a half open/half closed (45 degree) position. Open the ball valve approximately 45 degrees while draining the pipeline and assembly to allow water between the ball valve and valve body to drain. Leave the ball valve in this position for the winter to prevent freeze damage. The ball valve must be fully closed before the system is repressurized. **OPEN AND CLOSE BALL VALVES SLOWLY TO PREVENT DAMAGE TO THE SYSTEM CAUSED BY WATER HAMMER.**

Main Valve Draining Procedure 1/2" - 2" (15 - 50mm)

1. Close the main shutoff valve.
2. Open the inlet drain.
3. Open the inlet and outlet ball valves 45 degree (half open, half closed).
4. Open all testcocks.
5. Open the outlet drain.
6. Remove the cover and inlet check module until all water inside valve drains back out through inlet drain.
7. If you blowout the piping downstream of the backflow assembly using compressed air: Connect the air supply to the outlet drain and close the outlet ball valve. After clearing the system with air, partially open the outlet ball valve. Leave all drain valves, testcocks, and ball valves in half open/half closed position for the winter.
8. (RP UNITS ONLY) Loosen the relief valve cover to drain. Tighten when draining is complete.

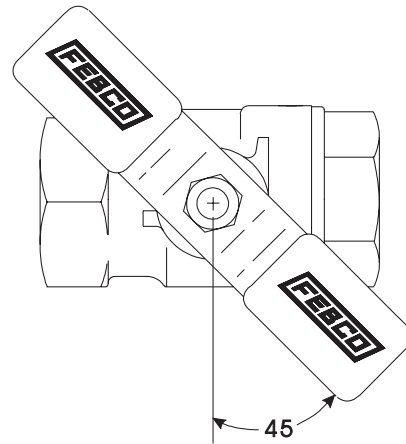

For additional information, visit our web site at: www.FEBCOonline.com

CALIFORNIA PROPOSITION 65 WARNING

WARNING: This product contains chemicals known to the State of California to cause cancer and birth defects or other reproductive harm. (California law requires this warning to be given to customers in the State of California.)

For more information: www.watts.com/prop65

Limited Warranty: FEBCO (the "Company") warrants each product to be free from defects in material and workmanship under normal usage for a period of one year from the date of original shipment. In the event of such defects within the warranty period, the Company will, at its option, replace or recondition the product without charge.

THE WARRANTY SET FORTH HEREIN IS GIVEN EXPRESSLY AND IS THE ONLY WARRANTY GIVEN BY THE COMPANY WITH RESPECT TO THE PRODUCT. THE COMPANY MAKES NO OTHER WARRANTIES, EXPRESS OR IMPLIED. THE COMPANY HEREBY SPECIFICALLY DISCLAIMS ALL OTHER WARRANTIES, EXPRESS OR IMPLIED, INCLUDING BUT NOT LIMITED TO THE IMPLIED WARRANTIES OF MERCHANTABILITY AND FITNESS FOR A PARTICULAR PURPOSE.

The remedy described in the first paragraph of this warranty shall constitute the sole and exclusive remedy for breach of warranty, and the Company shall not be responsible for any incidental, special or consequential damages, including without limitation, lost profits or the cost of repairing or replacing other property which is damaged if this product does not work properly, other costs resulting from labor charges, delays, vandalism, negligence, fouling caused by foreign material, damage from adverse water conditions, chemical, or any other circumstances over which the Company has no control. This warranty shall be invalidated by any abuse, misuse, misapplication, improper installation or improper maintenance or alteration of the product.

Some States do not allow limitations on how long an implied warranty lasts, and some States do not allow the exclusion or limitation of incidental or consequential damages. Therefore the above limitations may not apply to you. This Limited Warranty gives you specific legal rights, and you may have other rights that vary from State to State. You should consult applicable state laws to determine your rights. **SO FAR AS IS CONSISTENT WITH APPLICABLE STATE LAW, ANY IMPLIED WARRANTIES THAT MAY NOT BE DISCLAIMED, INCLUDING THE IMPLIED WARRANTIES OF MERCHANTABILITY AND FITNESS FOR A PARTICULAR PURPOSE, ARE LIMITED IN DURATION TO ONE YEAR FROM THE DATE OF ORIGINAL SHIPMENT.**



A Watts Water Technologies Company



USA: Fresno, CA • Tel: (559) 441-5300 • Fax: (559) 441-5301 • www.FEBCOonline.com
 Canada: Burlington, ON • Tel: (905) 332-4090 • Fax: (905) 332-7068 • www.FEBCOonline.ca